

CONEXIÓN Y CABLEADO / PANELES DE CONEXIÓN / MODULARES

WP-31UC

½ PANEL DE CONEXIÓN CARGADOR USB A HEMBRA



✓ Fácil instalación

ESPECIALMENTE RECOMENDADO EN:



Todos los sectores

DESCRIPCIÓN:

Paneles de conexión modulares para instalaciones de audiovisuales, aulas, salas de conferencias, etc. Cargador USB.



+ Info:
<https://fonestar.com/WP-31UC>

CARACTERÍSTICAS TÉCNICAS:

CARACTERÍSTICAS	Cargador USB. 1/2 panel de conexión. Bornas a tornillo.
CONECTORES	USB A hembra.
INDICADORES	Indicador luminoso de encendido
CONTROLES	Pulsador de encendido/apagado
SALIDAS	5 V CC (1.000 mA)
ALIMENTACIÓN	100-250 V CA
COLOR	Blanco (RAL 9003)
MEDIDAS	22'5 x 45 x 46 mm fondo



+ Info:
<https://fonestar.com/WP-31UC>

RevNo	Revision note	Rev-By	RevDate	Signature	Checked

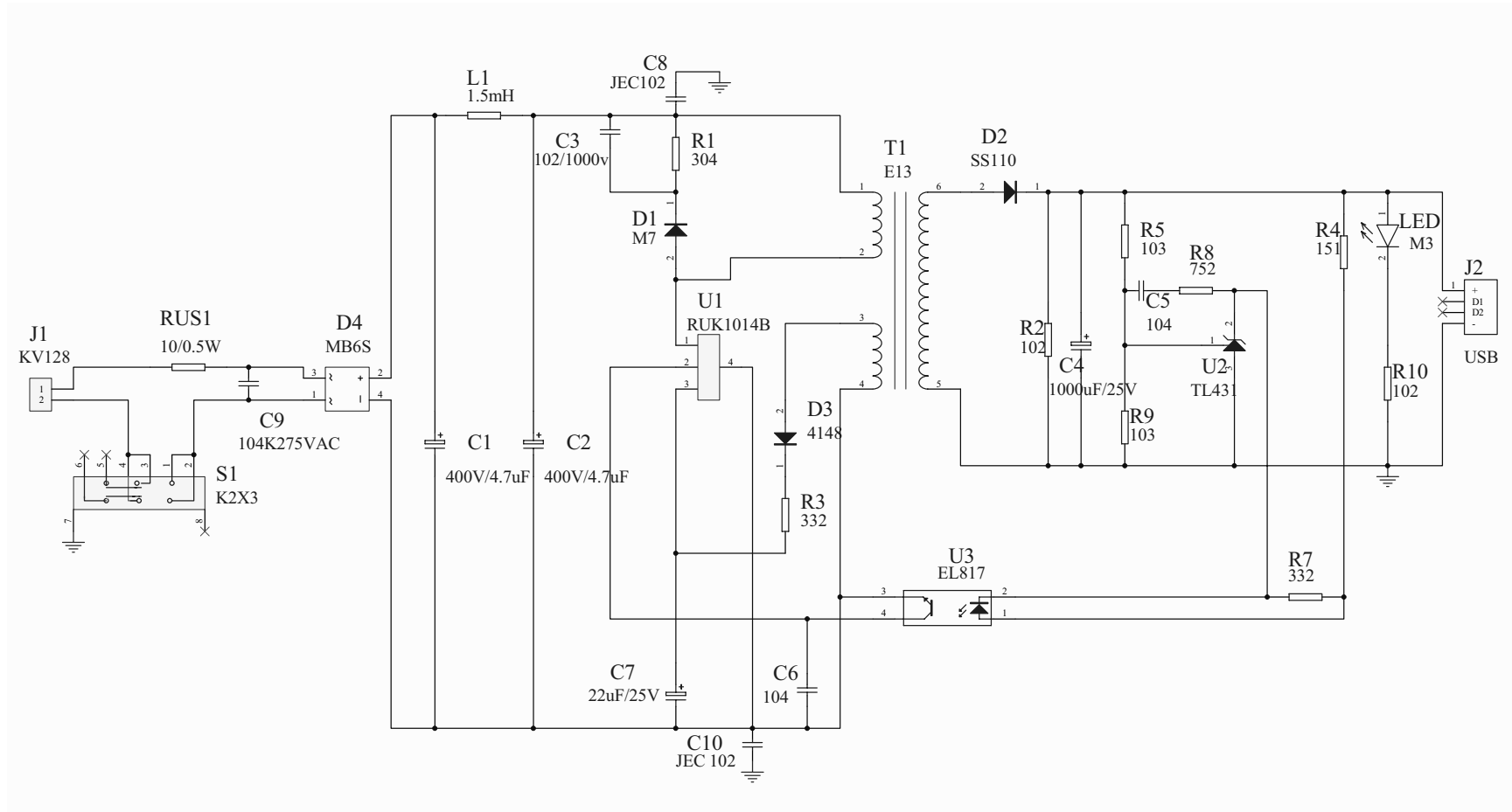

ITEM NO.	WP-31UC			
CUSTOMER NO.				
DESIGNED BY CH	DATE	121122	UNIT	MM
	SCALE	xx	VER.	1
NO.	Checked by			
APPR:	Approved by -date			